



## CONVEYOR-TYPE DISHWASHER MODEL: C800

Featuring easy for operation, reliable designs and value for money, **ecomax** machines are built to thrive in Asian conditions. Asia's eating patterns, high-density of meals to offer, and challenging ware washing conditions demand washing solutions that take these factors into account. Which is why our machines are designed to be reliable and effective enough to handle Asia's toughest washing requirements.



# CONVEYOR-TYPE DISHWASHER

## ECOMAX C800

*Adhering to the principle of "Quality First", C800 is the best conveyor-type dishwasher suitable for restaurants and Staff Canteen.*

**Operation directions can be exchanged on site for layout adjustment, without special tools and extra accessories.**

### HANDLING

—Easy and ergonomic, brings higher efficiency

- The compact structure minimizes the requirement of operating space.
- Tank cover filter and screen basket of large volume make it easy to collect dirt and avoid frequent cleaning.
- The wash and rinse arms can be taken out and inserted without tools to simplify cleaning.
- Clear operating panel is easy to be operated and minimizes the requirement of training.
- The digital temperature display makes it easy to monitor.
- The inlet water pressure can be easily regulated by valve according to pipeline situation.
- Automatic overflow function of wash tank brings easy drainage operation.

### WASH RESULT

—High performance ensures incomparable hygiene

- Patented anti-clog Nozzle Fan wash nozzles provide a substantially broader and more precise spraying pattern.
- High-power heaters ensure optimum washing temperature, even with cold water inlet and under continuous operations.
- Temperature control function guarantees rinse temperature to achieve optimum washing result.
- Less requirements for fresh water and rinse aid by precise rinse, reducing running cost.

### RELIABILITY

—Multi-protection design expands service life

- Automatic stop feature of pump and drive motor avoids hot water splashing when door is opened during the operation.
- The drive motor with double protections makes safe transmission.
- The float switch ensures reliable water level control to avoid dry heating.

### INSTALLATION AND SERVICE

—Easy and economic, brings time and cost saving

- Simple water supply/drain connections can significantly lower service cost.
- All the key components can be maintained in the front of the machine, which makes it very easy to maintain without moving the machine.

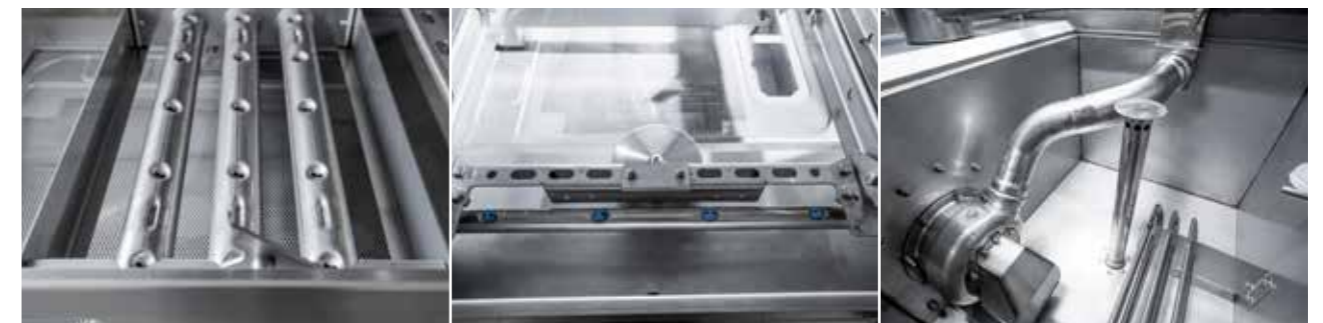

Need to purchase from third party: exhaust hood/operation tables/shower/racks/detergent/rinse aid/dispensers

**ecomax**  
by **HOBART**

**ecomax**  
by **HOBART**



## DRAWINGS

Model **C800** Conveyor-type Dishwasher

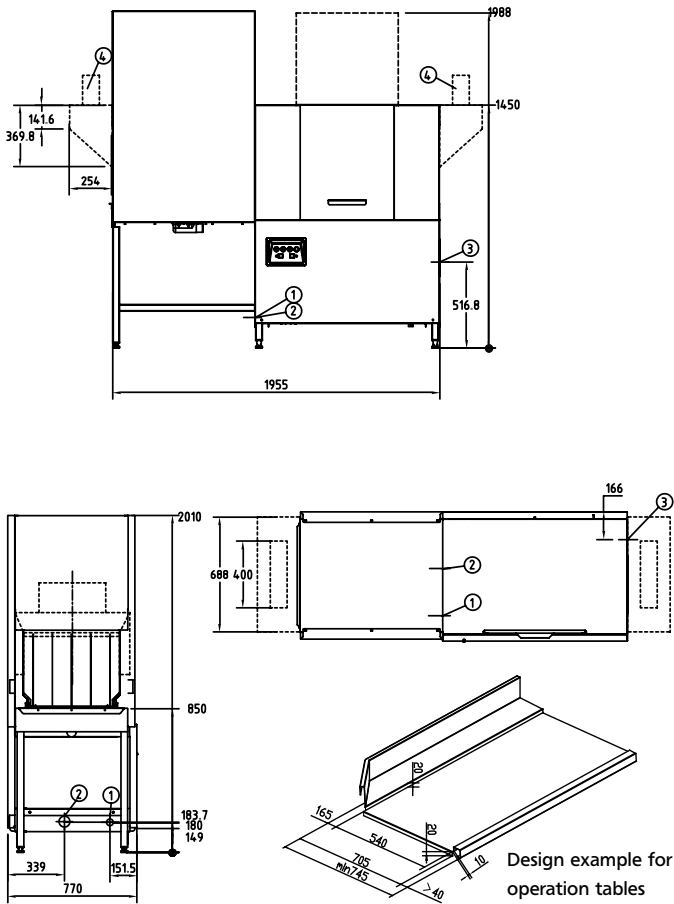

water filling    drain    electrical connection    Exhaust hood (purchase from third party)

## TECHNICAL DATA

SPECIFICATION	UNIT	C800
Wash capacity	racks/h	200
Wash temperature	°C	55-65
Rinse temperature	°C	80-90
Wash tank volume	L	105
Water consumption	L/rack	1.75
Water inlet temperature	°C	10-82
Water inlet pressure	bar	1.5-6
Wash pump	kW	1.5
Tank heating	kW	12 (or steam)
Booster heating	kW	30 (or steam)
Total loading	kW	44 (2-steam)
Power supply	V/Hz/Ph	380/50/3N~
Loading height	mm	440
Rack size	mm	500x500
Dimensions (WxDxH)	mm	1105x770x1450
<b>OPTION: DRYER</b>		
Air circulation	m <sup>3</sup> /h	510
SST fan	kW	0.75
Electric loading	kW	4.5 (Electric)
Steam consumption	kg/h	10 (steam)
Dimensions (WxDxH)	mm	850x770x2010

A registered trademark of HOBART GmbH  
Member of the *ITW* Food Equipment Group

ITW FEG (HK) Ltd  
HongKong  
Tel: +852-2341 9315

Hobart International (S) Pte Ltd  
Singapore  
Tel: +65-6846 7117

ITW India Pvt. Ltd.  
Gurgaon, India  
Tel: +91-9818004147

Hobart (Japan) K.K.  
Tokyo, Japan  
Tel: +81-3-5767 8670

Hobart Korea LLC  
Seoul, Korea  
Tel: +82-2-3443 6901

Hobart (Thailand)  
Bangkok, Thailand  
Tel: +66-2-675 6279