

Drawer Chiller

Drawer Chiller Slide-In / Free Standing

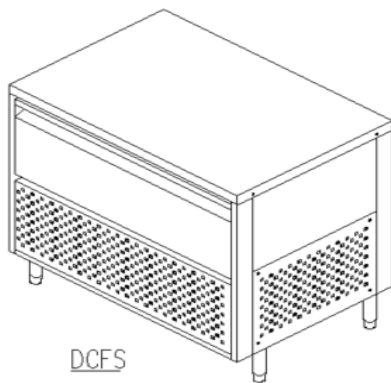
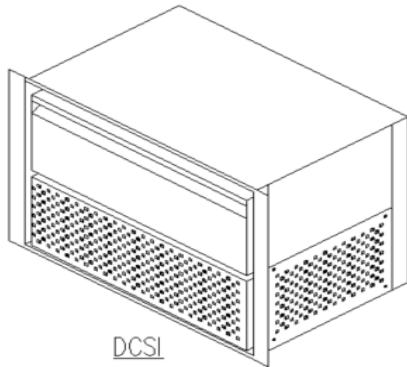

Standard Features:

- Full 304 Stainless Steel Construction
For ease of cleaning
- Removable Access Panel
For easy maintenance
- Hold cold products at optimum serving temperature
- Thermostatic Control
- For efficient temperature control

Specifications

The Fabristeel Drawer Chiller is designed to hold pre-packed coleslaw in compliance with the “First In, First Out” principle, to maintain the freshness of the product. This unit is specially insulated to minimise heat transfer.

With Fabristeel Drawer Chiller, food safety is never compromised.

Available Models:

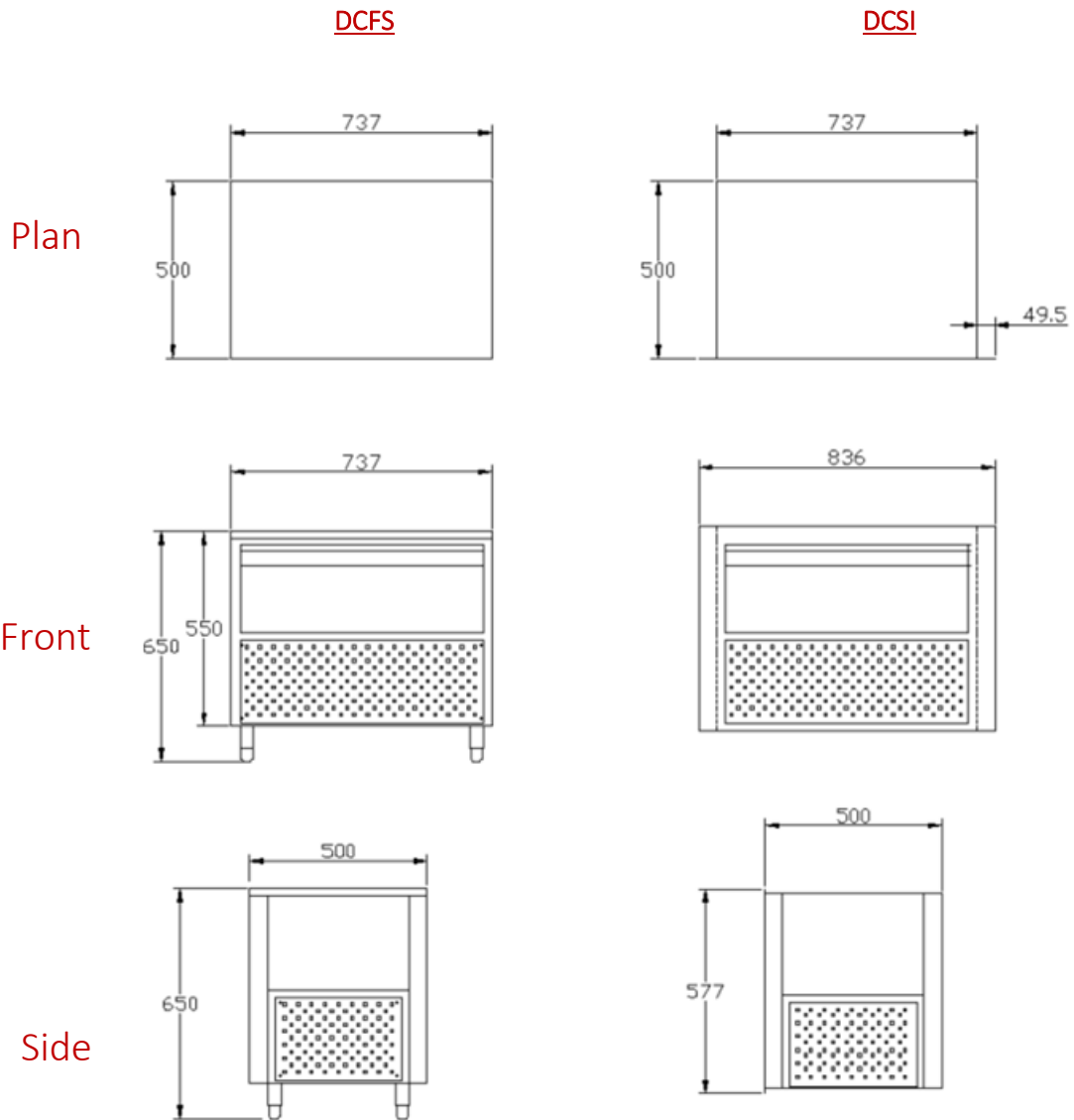

Product Code	Item Code		Dimension(mm)			Electrical Data					Shipping Weight (kg)
	Non CE	CE Version	Width	Depth	Height	Volt	Phase	Hertz	Watts	Amps	
DCFS Free standing	F70-203	n/a	737	500	650	230	1	50	250	0.8	90
DCSI Slide-In	F70-266	n/a	836	500	577	230	1	50	250	0.8	90