

Chest Freezer

Chest Freezer CF



Standard Features:

- Full Stainless-Steel Construction
For ease of cleaning
- Easily Removable Top Section
For storage and ease of cleaning
- 4" Swivel Casters
Provide mobility when fully loaded
- Thermostatic Control
For efficient control of temperature

Specification

The Fabristeel Chest Freezer is designed to hold supplies of frozen food and it is to be located beside the fryer. The freezer offers unrivalled space and volume for long term storage. It is also designed to withstand the toughest condition with its fully constructed stainless steel body and a lightweight lid for easy access to the frozen food. With Fabristeel Chest Freezer, food safety is never compromised.

Chest Freezer



Chest Freezer

Plan

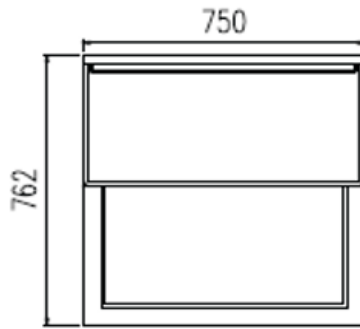

Front View

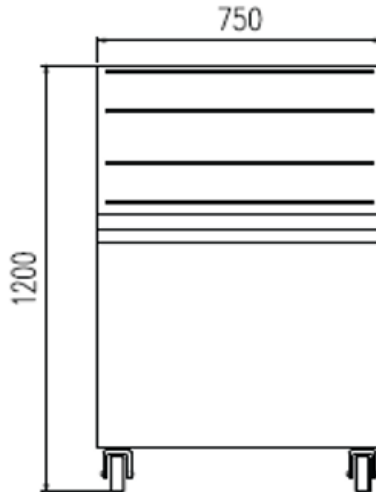

Section

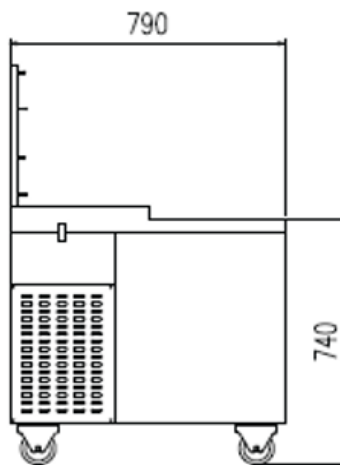

Product Code	Item Code		Dimension(mm)			Electrical Data					Shipping Weight (kg)
	Non-CE	CE Version	Width	Depth	Height	Volt	Phase	Hertz	Watts	Amps	
CF-Chest Freezer	F70-244	n/a	750	790	1200	230	1	50	250	1	170